

Reactochem

Reaction Unit

Filter Reactor

Nutsche Filter

Gas Scrubber

Thin Film Evaporator

Short Path Evaporator

Complete Package

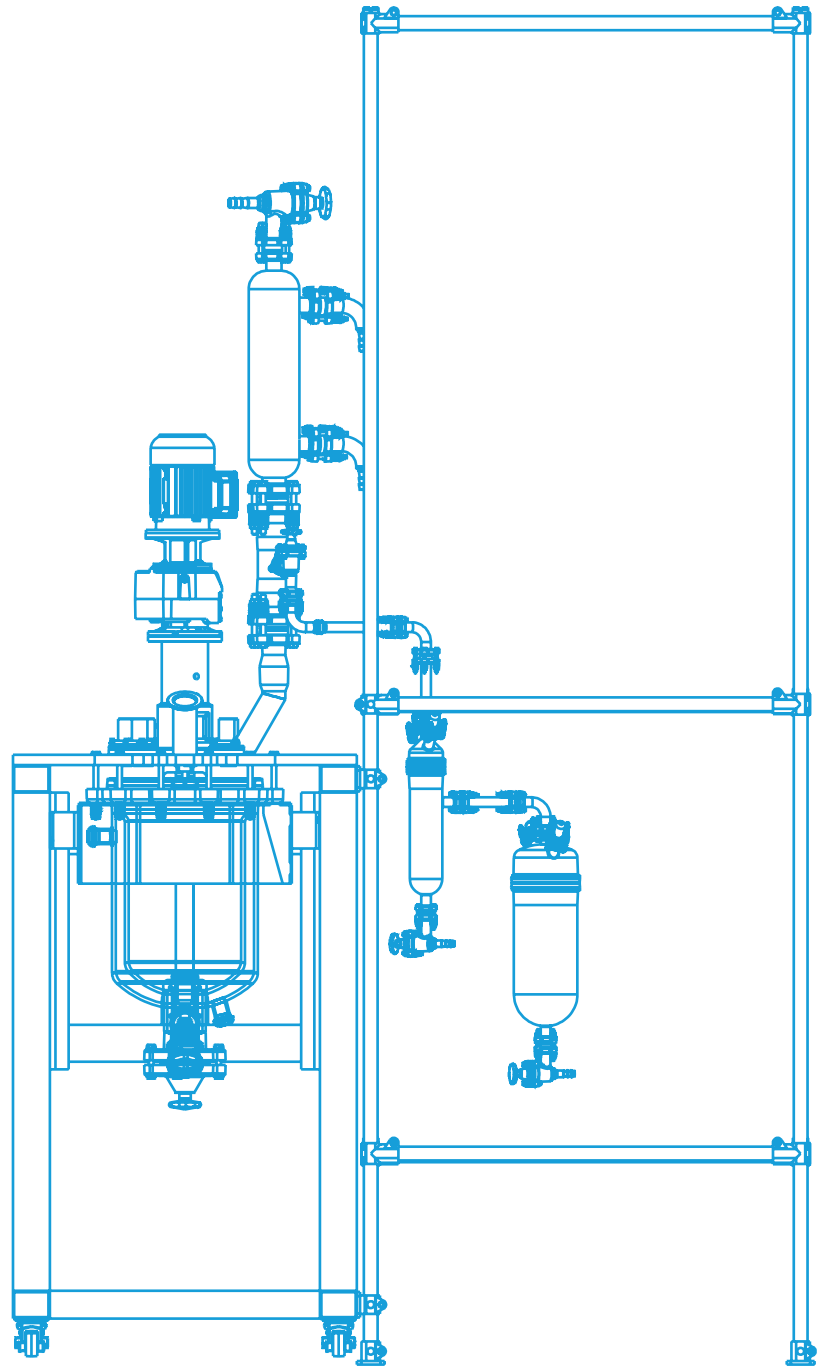

Product Overview 2024

DN400/DN450
30/50/100 Lt.



1 Electrical Motor & Reducer



High quality electric motor and reducer are ordered with the ex-proof class and power values requested by the customer.

Reducer

- *Monoblock body design
- *Provision of 2 and 3 stages in the same body
- *Reduction up to 6 stages with additional reducer coupling
- *Bearing solutions for high radial and axial loads
- *Different output flange options

3 Mechanical Seal

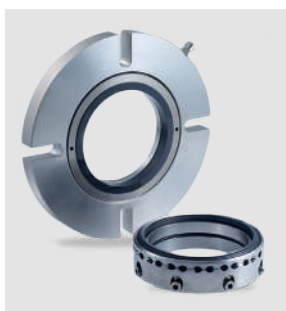

- *For top entry drives, on request side drive possible
- *Dry-running
- *Outboard mounted
- *Multiple springs rotating
- *Independent of direction of rotation

4 Stirrer Shafts

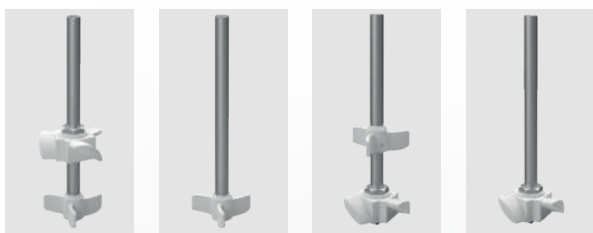

- *316ti Stainless Steel Shaft
- *PTFE - Chemical Resistant Stirrers
- *Can be ordered with different combinations

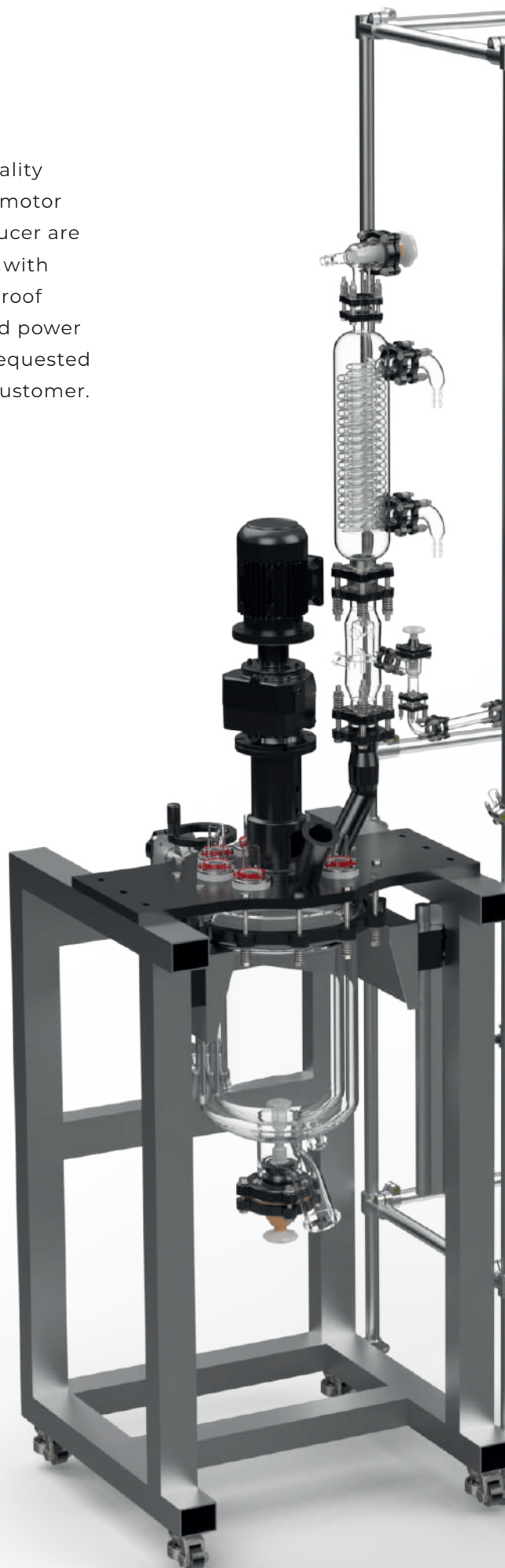

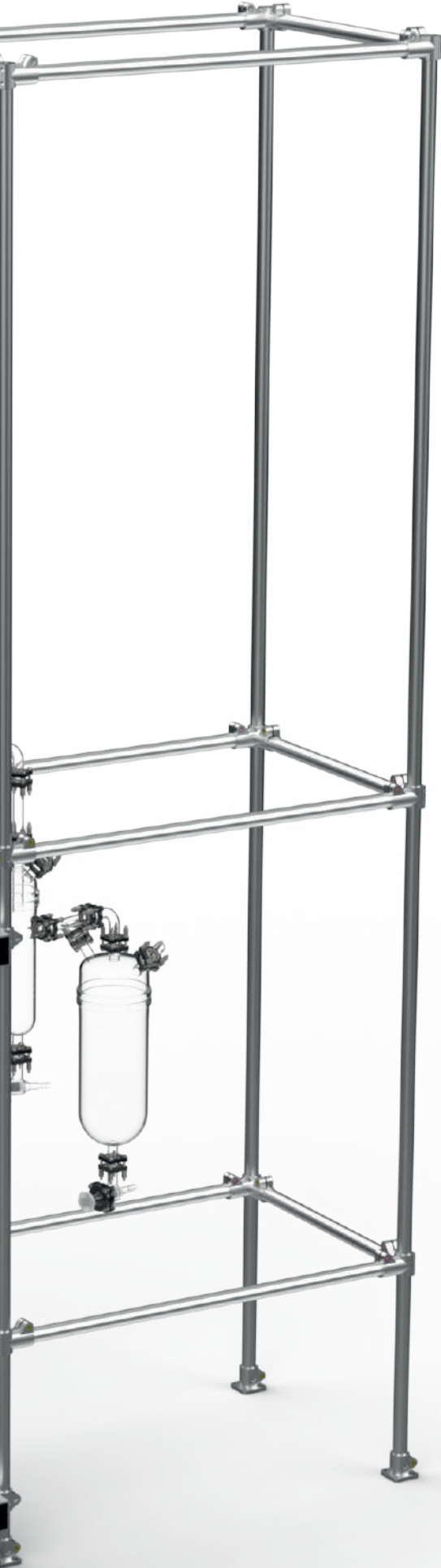

5 Condenser



Condenser options in different shapes and sizes

6 Clamps



Manufactured with lightness in mind, the aluminum stand is coated with phosphate to protect it from corrosion and external effects.

7 Adjustable Stand Design

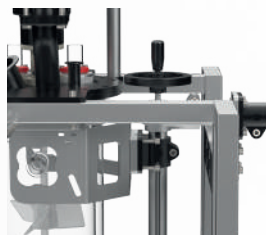

Manufactured with lightness in mind, the aluminium stands is coated with phosphate to protect it from corrosion and external effects.

8 Unique Design Cover



Stainless steel 316 ti cover specially designed for sealing



Overhead Stirrer



- Suitable for use in areas at risk of explosion, conforms with RL94/9/EC ATEX100A
- Speed control range adjustable R=00 to 0
- Torque increase during speed reduction
- Can be set while stationary
- Linear adjustment
- Multiple adjustment options
- Accurate reproducibility
- IEC mounting dimensions for drive and output sided providing extensive combination options
- Low noise operation 58-70 dB (A)
- Optimum transmission with synthetic traction fluid
- Can be overloaded briefly by up to 10 times the nominal torque
- Variable installation position
- Robust all-metal design.

Working principle

Horizontal ball turning axis
=output speed $n_2 \text{ min-1} = 0$

Maximum inclination of virtual ball turning axis
=output speed $n_2 \text{ max}$
=0.5 x input speed n_1

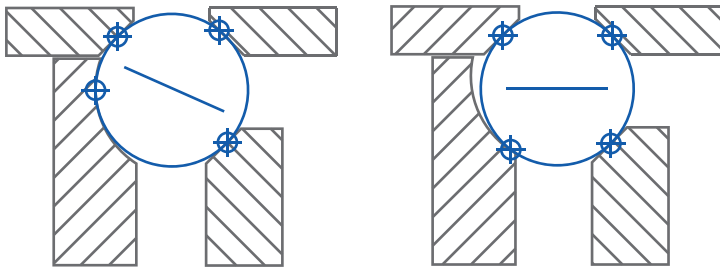

Reducer

- *Monoblock body design
- *Provision of 2 and 3 stages in the same body
- *Reduction up to 6 stages with additional reducer coupling
- *Bearing solutions for high radial and axial loads
- *Different output flange options

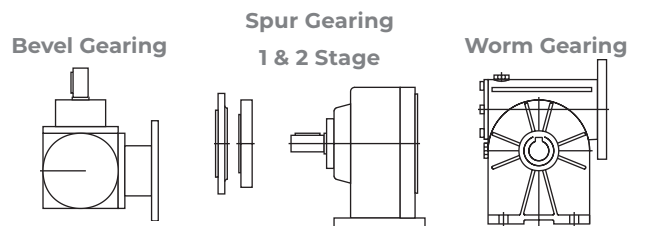
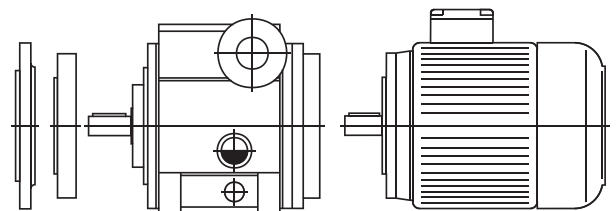



Mechanical Seal

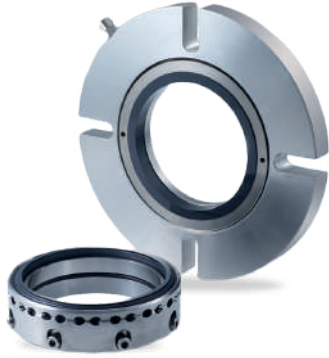

Operating range

- *Shaft diameter:
d1 = 25 ... 220 mm (0,98" ... 8,66")
- *Pressure: p1 = vacuum ... 6 bar (87 PSI)
- *Temperature:
t1 = -20 °C ... +200 (250*) °C
(-4 °F ... 392 (482*) °F)
- *Sliding velocity: v_g = 0 ... 2 m/s (0 ... 6 ft/s)
- *Axial movement: ±1.5 mm
- *Radial movement: ±1.5 mm

For applications beyond this range, please inquire.

*** without cooling flange**

in PTFE compound with 2 encapsulated ball bearings in s/s. The planes of the ceramic seals can be used without oil and discover a high gas tightness. The co-rotating inner sleeve (in PEEK or Hastelloy HC4) permits the use of stirrers in different materials (particularly suited for coated stirrers).

max. 800 rpm, max. Temp. 200°C

Stirrer Shaft

U-Shaped Type (PTFE)

Temperature resistance:
from -200°C yo +250°C

Chemical resistance:
+++ universal

Propeller-Stirrer Shafts with 4 Blades (PTFE)

Temperature resistance:
from -200°C yo +250°C

Chemical resistance:
+++ universal

Maxi Propeller Stirrer Shafts (PTFE)

Temperature resistance:
from -200°C yo +250°C

Chemical resistance:
+++ universal

Combination Stirrer Shafts

Temperature resistance:
from -200°C yo +250°C

Chemical resistance:
+++ universal

Temperature resistance:
from -200°C yo +250°C

Chemical resistance:
+++ universal

Temperature resistance:
from -200°C yo +250°C

Chemical resistance:
+++ universal

*It can be designed specifically for your process with mixing tips and various combinations.



Adjustable Stand Design

“Crafted for exceptional versatility and unwavering stability, our stainless steel stand stands as a testament to meticulous engineering and robust design principles. Engineered to withstand the harshest chemical environments, it forms an impregnable barrier against corrosion, oxidation, and a spectrum of environmental stressors.

At its core lies a commitment to excellence, leveraging the superior properties of 316ti stainless steel. This alloy not only ensures unparalleled corrosion resistance but also reinforces structural integrity under extreme temperatures and pressures.

Our innovative design approach integrates ergonomic elements that prioritize both functionality and user comfort. Each component is meticulously crafted to facilitate seamless operation and precise positioning, whether in bustling industrial settings or exacting laboratory environments.

Ideal for research institutions, chemical laboratories, and industrial facilities alike, our stainless steel stand represents a pinnacle of reliability and adaptability. It is a standout choice for professionals seeking uncompromising quality, durability, and performance in their chemical reactor solutions.”

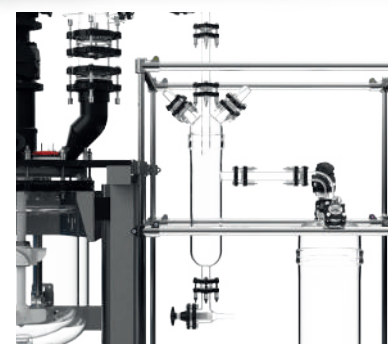
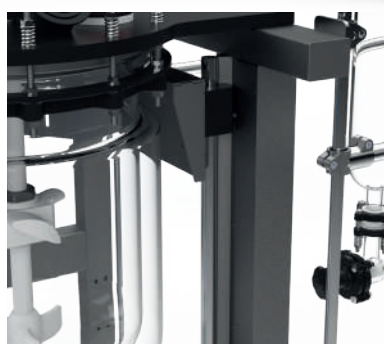

Accessible Design:

Ensure the manual adjustment mechanism is accessible and easy to reach for operators, considering the layout and operational needs of the reactor facility.

Ergonomic Design:

Design the manual controls with ergonomic considerations to minimize operator fatigue and discomfort during prolonged use.

All Glass Pieces:

All glass parts can be selected as borosilicate and quartz for your needs and process requirements.



Unique Design Cover



“The reactor cover, meticulously crafted from 316ti stainless steel, epitomizes our dedication to maximizing efficiency and customization for every customer. Designed with a standard open entrance, each cover is meticulously tailored to meet specific customer requirements, ensuring seamless integration with existing systems and operational workflows.

Our approach emphasizes not only immediate functionality but also future usability and adaptability. The cover is engineered for effortless closure and secure sealing, facilitating ease of maintenance and potential upgrades as operational needs evolve over time.

Beyond its robust construction and corrosion resistance, the 316ti stainless steel ensures superior durability and longevity, capable of withstanding harsh chemical environments and high temperatures with minimal maintenance. This material choice underscores our commitment to quality and reliability, providing customers with a steadfast solution that enhances operational efficiency and safety.

Leveling Casters



*Brackets: Pressed steel plate, double ball bearing with hardened bearing seats in the swivel head, ivory-colored aluminum frame, height adjustment with integrated orange handle or spanner, anti vibration NBR pad

*Surface Treatment: Powder coating, zinc plated

*Wheel: Nylon 66 (Shore D70), No bearing

60~1,500kg -10~90°C

* Recommended Load = Load Cp. x2

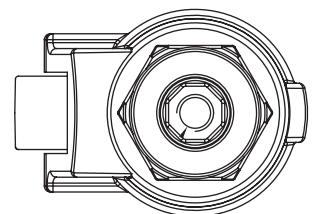
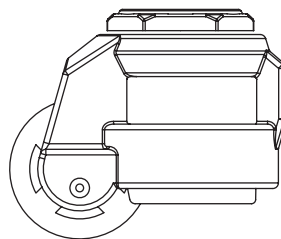
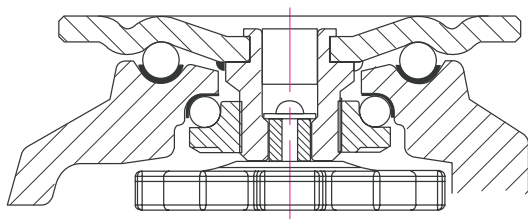

Swivel	Wheel type	mm	mm	Kg	mm	mm	mm	mm	mm
GD-60-F	NYN	50	25	280	82+10	36	73 x 73	58 x 58	7 or 8.5



Condenser

Cooler with tubusses 2xDN25

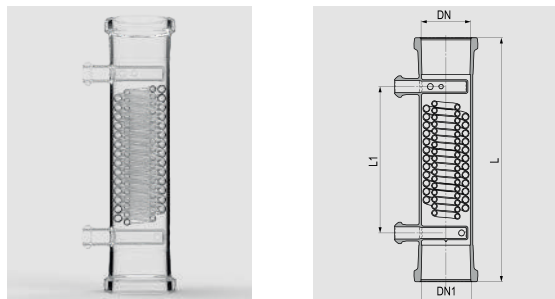

DN	DN 1	L mm	L1 mm	F m ³
100	100	500	300	0,3

F – heat-exchanging area

Cooler with tubusses 2xDN25

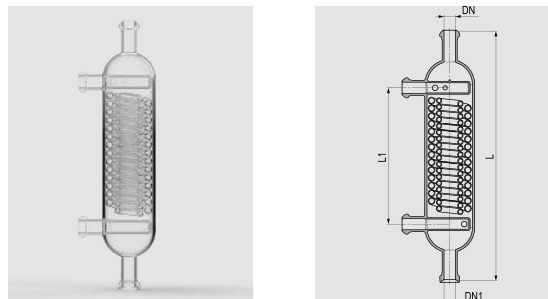

DN	DN 1	L mm	L1 mm	F m ³
25	25	550	300	0,3

F – heat-exchanging area

Cooler with tubusses 2xDN25

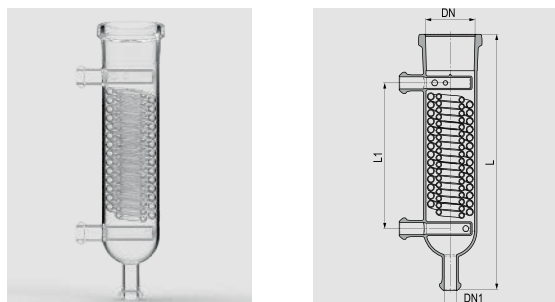

DN	DN 1	L mm	L1 mm	F m ³
100	25	525	300	0,3

F – heat-exchanging area

Cooler with tubusses 2xDN25

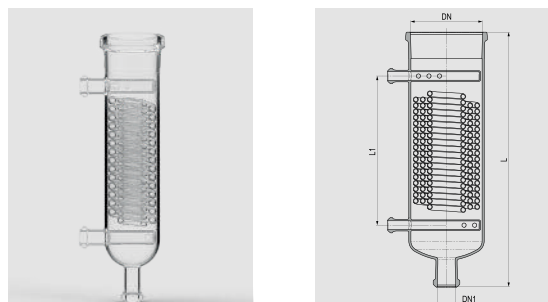

DN	DN 1	L mm	L1 mm	F m ³
150	25	650	405	0,7

F – heat-exchanging area

Reflux

Distilling head with overflow

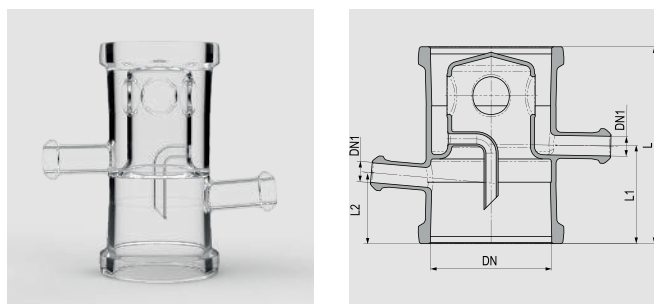

DN	DN 1	L mm	L1 mm	L2 mm	Kg
100	25	250	125	90	1,9
150	25	250	125	90	3,1

Reflux head with built-in pneumatic valve

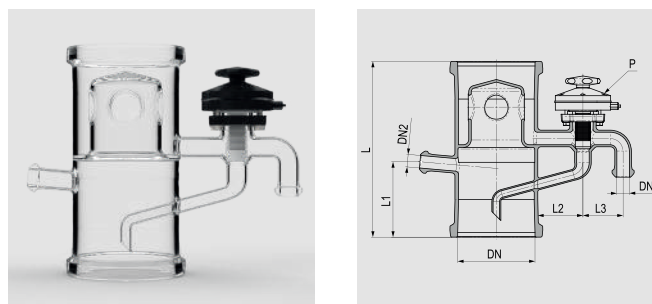

DN	DN 1	DN 2	L mm	L1 mm	L2 mm	L3 mm
100	25	25	325	150	90	90
150	25	25	350	150	90	80



DN 60

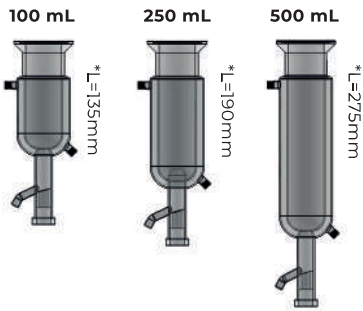

DN 100

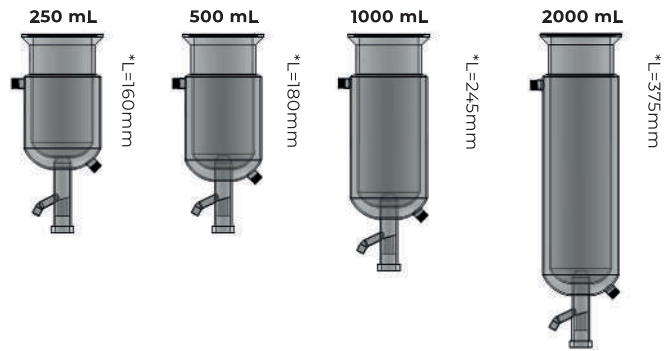

DN 150

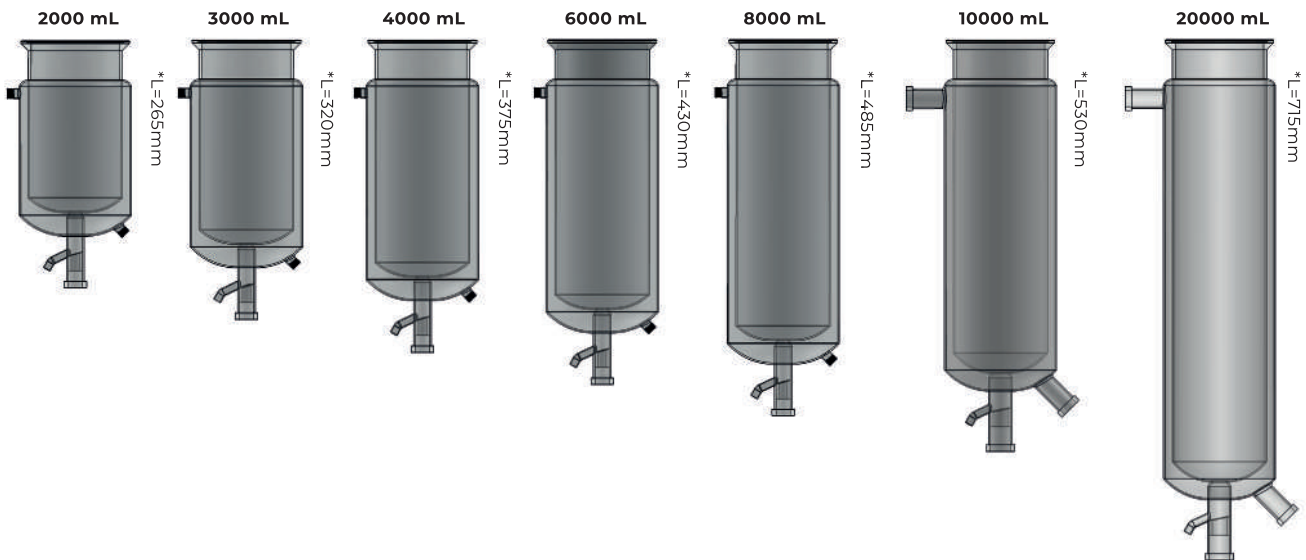

DN 200

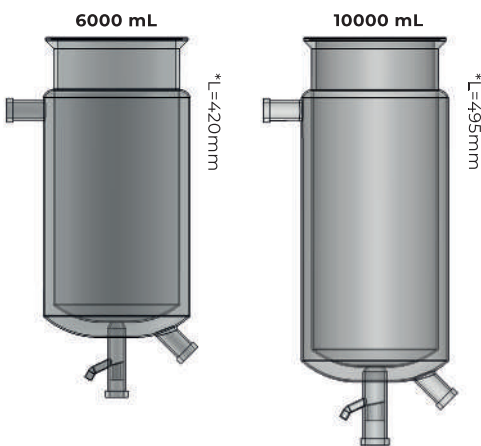

DN 300

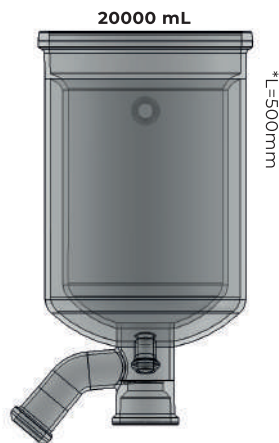

DN 400

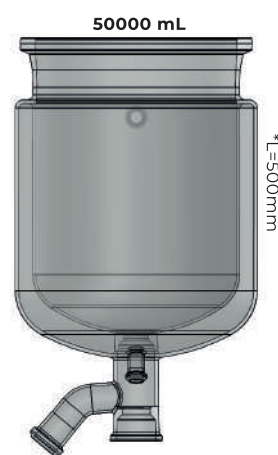

DN 450

